

FOM, FOS 850, FOS 1300, FOS 850/1300

## ***Fiber Optic Power Meter Fiber Optic Light Source***

*Instruction Sheet*

### ***Introduction***

The Fiber Optic Power Meter (FOM) measures optical power on fiber optic cables. An FOM indicates any power loss on tested cables using any digital multimeter (DMM) or graphical multimeter (GMM) that has a 10 M $\Omega$  input impedance, standard diameter banana jacks, and mVdc capability. The Fiber Optic Light Source (FOS) is used as a light source with the FOM or other fiber optic meters.

### ***Safety Information***

All FOSs have been tested according to IEC 1010-1 and IEC 825-1 and meet all requirements for a Class 1 LED Product.

To ensure the FOS is used safely, read the following warnings:

#### **Warning**

**To avoid possible exposure to hazardous invisible LED radiation and to prevent eye damage:**

- **Never look directly into the aperture (Figure 2) of the ST connector.**
- **Do not open the case; no serviceable parts are inside. Send the source to a authorized service center for calibration or repair.**
- **Do not adjust or modify the source; LED sources may exceed Class 1.**
- **Do not use magnification at the ST connector output.**
- **Caution - Use of controls or adjustments, or performance of procedures other than those specified herein may result in hazardous radiation exposure.**

# FOM Features

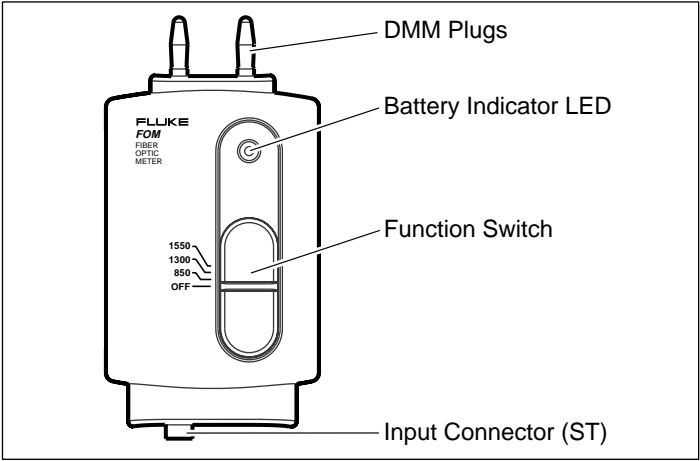

aj1f.eps

Figure 1. Fiber Optic Power Meter

# FOS Features

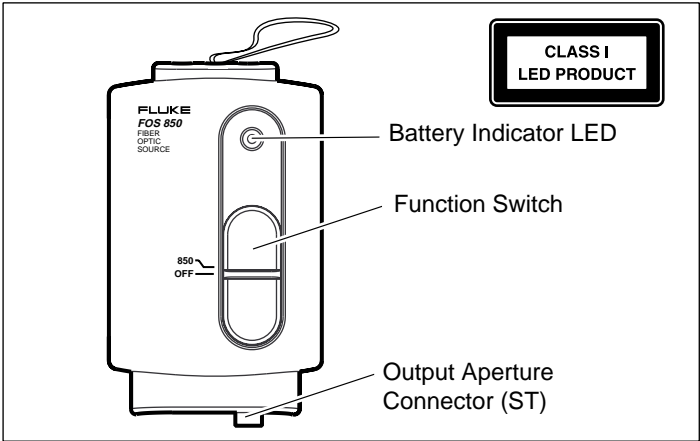

aj2f.eps

Figure 2. Fiber Optic Light Source (850 Source Shown)

# Clean Connectors

Turn the FOS off before cleaning. To ensure proper operation, clean internal portion of connectors with a low-lint optical grade cleaning swab and optical grade alcohol, and a can of filtered compressed air.

# Measuring dB Loss

To measure dB loss, refer to Figures 3 and 4 and do the following:

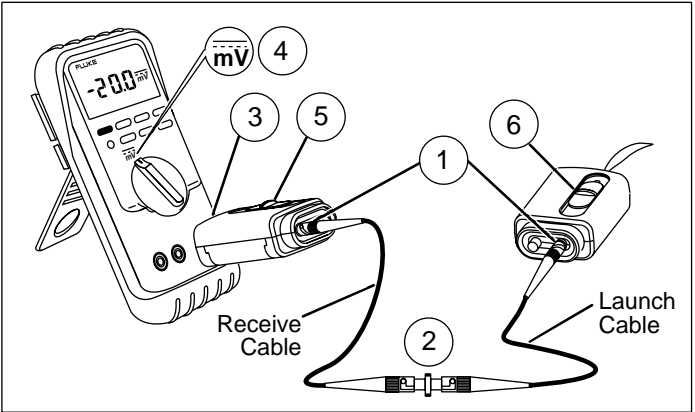

**Figure 3. Measuring Output for Source Reference**

1. Clean the connectors and fiber ends with alcohol and check for fiber bends. Connect the receive cable to the FOM and the launch cable to the FOS.
2. Connect the launch and receive cables with a coupling (P/N 602810 or equivalent).
3. Plug the FOM into the DMM or GMM with the red polarity indicator aligning with the voltage input.
4. Select mVdc on the DMM.
5. Select the desired wavelength on the FOM.
6. Select the desired wavelength on the FOS and stabilize (20 minutes).
7. Record the dBm reference measurement (1 dBm = 1 mVdc) on the DMM display (or if you have a DMM with a reference function, activate the reference function).

### Note

*The reference measurement on the display should closely match the output level specified for the optical source (approximately -20 dBm into multimode fiber).*

8. When finished, disconnect the launch and receive cables from the coupling.

### Note

*To measure dB loss accurately, do not disturb the connections to the FOM and FOS after measuring the source output.*

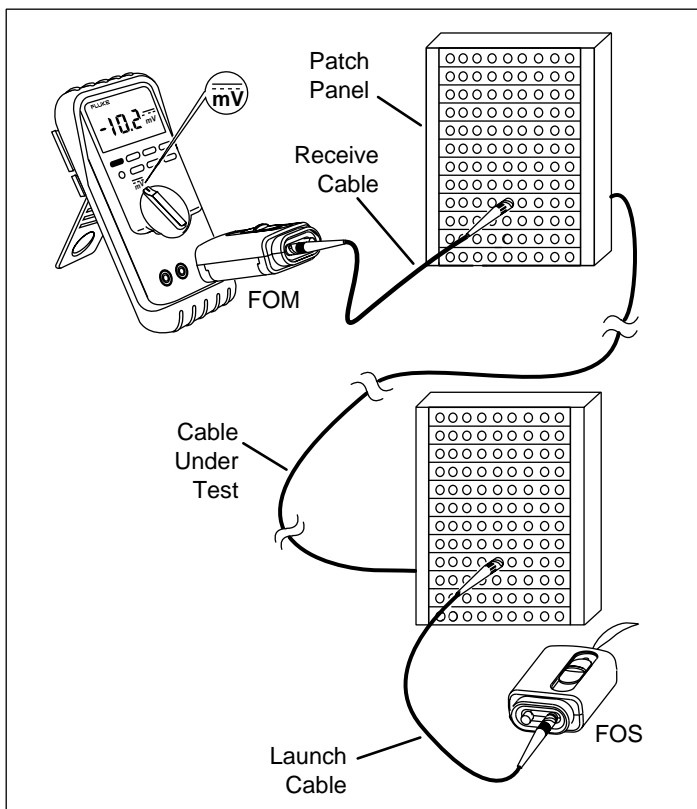

aj4f.eps

**Figure 4. Measuring Optical Loss**

9. Connect the launch and receive cables to cable under test; record the measurement. (Cables must be the same fiber type as the cable under test.)
10. Subtract the optical loss measurement from the dBm reference measurement to get the actual dB loss. (If the DMM has an activated reference function, the reading is dB loss.)

### ***Checking the Battery***

If the LED is on continuously, the battery is good.

If the LED blinks or is not on, replace the battery.

# Replacing the Battery

To replace the battery, refer to Figure 5.

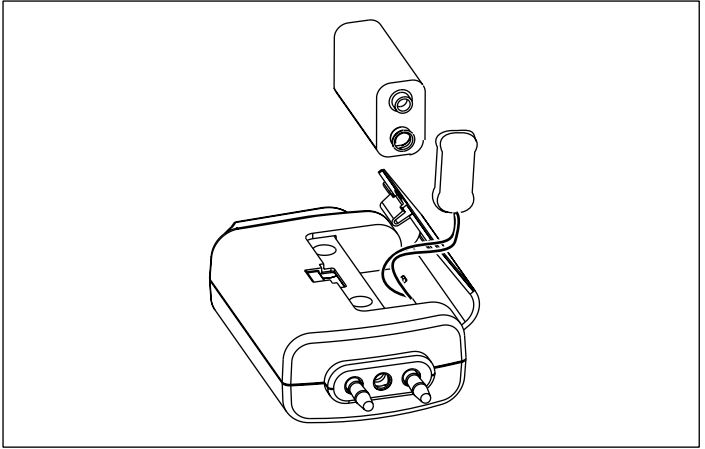

aj5f.eps

Figure 5. Battery Replacement

## General Specifications

### Power Meter Specifications

Output:	1 mV per 1 dB
Input Connector Type:	Fixed ST
Photodetector Type:	Germanium
Application Range:	800 to 1600 nm
Calibrated wavelengths:	850, 1300, and 1550 nm
Acceptable fiber types (sizes):	9/125 to 100/140 $\mu\text{m}$
Operating range:	+3 to -50 dBm
Maximum power level:	+5 dBm
Absolute accuracy:	$\pm 0.25$ dB, (Specified at 25°C & -10.0 dBm per NIST standard)
Relative accuracy:	$\pm 0.15$ dB, (Specified over any 10 dB within measurement range)
Repeatability:	$\pm 0.04$ dB
Battery type:	9V alkaline, NEDA 1604A or IEC 6LR61
Battery life:	16 hours minimum, 100 hours typical, 9V alkaline
Low battery indication:	Blinking LED indicator
Operating temperature:	0 to +40°C
Storage temperature:	-20 to +70°C
Humidity:	0 to 40°C, up to 75% RH
Electromagnetic Compatibility:	Total Accuracy =
RF Field $\leq 1$ V/m	Specified Accuracy
RF Field = 3 V/m	Specified Accuracy + 2.5 dB

## Source (850, 1300, 850/1300) Specifications

Type:	Infrared LED
Wavelength:	850 ± 30 nm 1300 ± -40/+50 nm 850/1300 ± 30 nm, -40/+50 nm
Output power:	-20 dBm, nominal into 62.5/125 micron multimode fiber
Output connector type:	Fixed ST
Beam divergence:	0.3 radians
Pulse duration:	Continuous wave
Maximum output:	200 μW (radiated into free space)
Stability:	±0.2 dB per 8 hours at 20°C after 20 minute warmup
Temperature coefficient:	-0.08 dB per °C, < 18°C or > 28°C
Battery type:	9V alkaline, NEDA 1604A or IEC 6LR61
Battery life:	16 hours minimum, 24 hours typical, 9V alkaline
Low battery indication:	Blinking LED indicator
Operating temperature:	0 to +40°C
Storage temperature:	-20 to +70°C
Humidity:	0 to 40°C, up to 75% RH

## Service

For service information in the U.S.A., call 1-800-825-9810.  
Outside the U.S.A., contact an authorized service center.

To locate an authorized service center, visit us on the World Wide Web: [www.fluke.com](http://www.fluke.com) or call Fluke using any of the phone numbers listed below:

1-800-443-5853 in U.S.A and Canada

31 40 267 8200 in Europe

206-356-5500 from other countries

# *Fiber Optic Meter Fiber Optic Source*

## *Service Information*

### **Warning**

**To avoid injury: do not service the FOM or FOS unless you are qualified to do so. The service information provided in this document is for the use of qualified personnel only.**

### **Caution**

**The FOM and FOS contain parts that can be damaged by static discharge. Follow the standard practices for handling static sensitive devices.**

### ***Introduction***

This *Service Information* provides the following service information for the Fiber Optic Meter (hereafter referred to as the FOM) and the Fiber Optic Source (hereafter referred to as the FOS).

- Parts and warranty service information
- Specifications
- Schematic
- Cleaning procedures
- Required equipment
- Performance tests
- Procedures for disassembling and reassembling the FOM and FOS
- Calibration adjustments
- Parts and accessories lists

For operating instructions, refer to the *Fiber Optic Meter/Fiber Optic Source Instruction Sheet*.

### ***Parts and Warranty Service***

The FOM and FOS are warranted to be free from defects in material and workmanship for one year, while under normal use. Parts and repairs are warranted for 90 days.

Refer to the *Instruction Sheet* for the complete warranty statement.

To order parts, receive operating assistance, or get the location of the nearest Fluke distributor or Service Center, call:

800-44FLUKE (800-443 5853) in the U.S.A. and Canada.

(31 40) 267 8200 in Europe

+ 1 206-356-5500 from other countries

Address correspondence to:

Fluke Corporation

P.O. Box 9090

Everett, WA 98206-9090

U.S.A.

Fluke Europe B.V.

P.O. Box 1186

5602 B.D Eindhoven

The Netherlands

### ***Specifications***

Accuracy is specified for a period of one year after calibration, at 18°C to 28°C (64°F to 82°F) with relative humidity to 75%.

Specifications are shown in Tables 1 and 2.

**Table 1. FOM Specifications**

<b>Output</b>	1 mV per 1 dB
<b>Input Connector Type</b>	Fixed ST
<b>Photodetector Type</b>	Germanium
<b>Application range</b>	800 to 1600 nm
<b>Calibrated Wavelengths</b>	850, 1300, and 1550 nm
<b>Acceptable Fiber Types</b>	9/125 to 100/140 $\mu$ m
<b>Operating Range</b>	+3 to -50 dBm
<b>Maximum Power Level</b>	+5 dBm
<b>Absolute Accuracy</b>	$\pm$ 0.25 dB (specified at 25°C -10 dBm per NIST standard)
<b>Relative Accuracy</b>	$\pm$ 0.15 dB, (specified over any 10 dB within measurement range)
<b>Repeatability</b>	$\pm$ 0.04 dB
<b>Battery Life</b>	9V alkaline, NEDA 1604A or IEC 6LR61
<b>Battery Type</b>	16 hours minimum, 100 hours typical, 9V alkaline
<b>Low Battery Indication</b>	Blinking LED indicator
<b>Operating Temperature</b>	0° to +40°C
<b>Storage Temperature</b>	-20° to +70°C
<b>Humidity</b>	0 to 40°C up to 75% RH

**Table 2. FOS Specifications**

<b>Type</b>	Infrared LED
<b>Wavelength</b>	850 $\pm$ 30 nm 1300 -40/+50 nm 850/1300 $\pm$ 30 nm, -40/+50 nm
<b>Output power</b>	-20 dBm, nominal into 62.5/125 micron multimode fiber
<b>Output connector type</b>	Fixed ST
<b>Beam divergence</b>	0.3 radians
<b>Pulse duration</b>	Continuous wave
<b>Maximum output</b>	200 $\mu$ W (radiated into free space)
<b>Stability</b>	$\pm$ 0.2 dB per 8 hours at 20°C after 20 minute warmup
<b>Temperature coefficient</b>	-0.08 dB per °C, < 18°C or > 20°C
<b>Battery Life</b>	9V alkaline, NEDA 1604A or IEC 6LR61
<b>Battery Type</b>	16 hours minimum, 24 hours typical, 9V alkaline
<b>Low Battery Indication</b>	Blinking LED indicator
<b>Operating Temperature</b>	0° to +40°C
<b>Storage Temperature</b>	-20° to +70°C
<b>Humidity</b>	0 to 40°C up to 75% RH

## Safety Information



The FOS is rated as a class 1 LED source per IEC 825.

## General Description

The FOM measures optical power on fiber optic cables. It indicates power loss on tested cables using any digital multimeter (DMM) or graphical multimeter (GMM™) that has a 10 M $\Omega$  input impedance, standard diameter banana jacks, and mVdc capability. The FOS is used as a light source with the FOM or other fiber optic meters.

## Low Battery Detection

For both the FOM and FOS, a steady, green LED indicates a good battery. A blinking LED indicates a low battery that needs to be replaced.

## Cleaning the Optical Connector

Most problems with optical power meters and light sources result from contaminated connectors. Therefore, always clean the connector before troubleshooting or calibration.

To clean the FOM or FOS ST connector, wipe the internal portion gently with an optical-grade swab dampened with optical-grade alcohol. To remove loose dirt and dust from the connector, use filtered, compressed air.

Always cover the connector with a dust cap when the unit is not in use.

## Equipment Required

The following equipment is required for servicing the FOM:

- 0-10V power supply
- Digital multimeter
- Optical power meter calibrated at 850, 1300, and 1550 nm traceable to NIST Standards
- 850 nm laser source; P<sub>O</sub> = -10 dBm
- 1300 nm laser source; P<sub>O</sub> = -10 dBm
- 1550 nm laser source: P<sub>O</sub> = -10 dBm
- Variable optical attenuator

- 2 ST/ST multimode fiber optic patch cables
- The following equipment is required for servicing the FOS:

- Calibrated FOM
- Digital multimeter
- One ST/ST multimode fiber optic patch cable

### **Performance Tests**

Use the following performance tests to confirm that the FOM or FOS is working properly. If the FOM or FOS fails any of these tests, it needs calibration adjustments or repair.

#### **FOM -10 dBm Checkout**

1. Turn on the FOM and the three light sources. Allow the FOM to warm up for 10 minutes. Allow the sources to warm up according to the manufacturer's specifications.  
  
Perform the remaining steps using the light sources in the following order: (1) 850 nm, (2) 1550 nm, and (3) 1300 nm.
2. Connect the light source to the reference power meter using a fiber optic patch cable.
3. Adjust the output of the source for a power meter reading of  $-10.00 \pm 0.05$  dBm. Record this reading as  $P_O$  (power out) to use in step 5.
4. Set the FOM switch to the wavelength position being tested.
5. Connect the FOM to the light source using the patch cable from step 2.  
  
Allow a few seconds for the reading to stabilize; then verify that the reading is  $P_O \pm 0.25$  dBm.
6. Disconnect the light source from the FOM.

#### **FOM -50 dBm Checkout**

1. Connect the 1300 nm light source to the optical attenuator.  
  
Connect the attenuator to the reference power meter using a second fiber optic patch cable.
2. Set the optical attenuator for a power meter reading of  $-50.00 \pm 0.05$  dBm. Record this reading as  $P_O$  to use in step 4.
3. Connect the FOM to the attenuator using the patch cable connected to the reference power meter.

4. Allow a few seconds for the reading to stabilize; then verify that the reading is  $P_O \pm 0.4$  dBm.
5. Turn off the DMM, FOM, and the light sources. Disconnect the FOM from the DMM. Disconnect the fiber optic patch cables from the attenuator, source, and FOM.

#### **FOS Checkout**

1. Connect the FOS to the calibrated FOM with a patch cable.  
  
Turn the FOS on to the wavelength being tested and let it stabilize for 20 minutes.
2. Connect the FOM to a DMM with at least 0.1 mV resolution.  
  
Turn the FOM on and set the switch to the wavelength being tested.
3. Verify that the FOS output is  $-20 \pm 0.5$  dBm ( $-19.5$  to  $-20.5$  mV on the DMM).
4. For a dual source, repeat steps 1 through 3 for each wavelength.

### **Disassembling and Reassembling the FOM and FOS**

To perform calibration adjustments for the FOM and the FOS, you must disassemble them. When you finish the adjustments, reassemble them. A Phillips-head screwdriver is required for disassembling and reassembling the FOM and FOS. To disassemble the FOM or FOS, proceed as follows:

1. Set the FOM or FOS switch to OFF.
2. Remove the battery door; then disconnect the battery.
3. Remove the two Phillips screws found under the battery door; then separate the top and bottom cases.
4. To remove the pca, remove the Phillips screw near SW1; then lift out the pca.

To reassemble the FOM or FOS, proceed as follows:

1. Reinsert the pca; then replace the screw that holds the pca.
2. Tuck the battery wires into the notch at the side of the battery compartment.

3. Tuck the battery wires down against the pca so they will not interfere with SW1.
4. Set SW1 to the off position.
5. Set the slide switch actuator on the top case to the OFF position. For the FOS, place the lanyard into the notch in the bottom case.
6. Put the top and bottom cases together; then replace the two screws under the battery door.

## **Calibration Adjustments for the FOM**

To ensure that the FOM performs to specifications, calibrate it annually using the procedure that follows.

Always perform the complete calibration adjustment procedure.

### **Preparing for Calibration**

To prepare for calibration, proceed as follows:

1. Remove the dust cap from the FOM.
2. Connect a voltage supply of  $8V \pm 1.0V$  dc to the FOM battery strap.
3. Set the FOM switch to the 1300 nm position.  
Allow the FOM to warm up for 10 minutes.
4. Allow all sources to warm up according to the manufacturer's specifications.

### **Coarse Calibration Adjustment**

Refer to the FOM drawing (Figure 1) for the locations of measurements and components.

1. Connect the 1300 nm light source to the attenuator input.  
  
Connect the attenuator output to the reference power meter. Set the attenuator for 0 dB attenuation. Set the 1300 nm light source for a power meter reading of  $-10 \pm 0.05$  dBm.

### *Note*

*For the remaining calibration adjustments, use the cable that was used in step 1 for connecting the attenuator to the reference power meter or the FOM. To reduce errors, limit the movement of the cable when making connections between the attenuator and the reference power meter or the FOM. To limit cable movement, coil and tape the excess cable to the work surface.*

2. Connect the attenuator output to the FOM.
3. Measure  $V_{det}$  between U1 pin 7 and the analog ground reference at U1 pin 5 with the DMM. (See Figure 1.)
4. Adjust R2 for an output on the DMM of  $0.23 \pm 0.01V$  dc.

### **1300 nm Fine Calibration Adjustment**

1. Connect the 1300 nm light source to the attenuator input. Connect the attenuator output to the reference power meter. Set the attenuator for 0 dB attenuation. Set the 1300 nm light source for a power meter reading of  $-10 \pm 0.05$  dBm.  
Record this reading as  $P_O$  to use in step 3.
2. Connect the attenuator output to the FOM. Connect the FOM to the DMM.
3. Adjust R10 for an output on the DMM of  $P_O \pm 0.05$  dBm.
4. Connect the attenuator output to the reference power meter. Set the attenuator for a power meter reading of  $-45 \pm 0.05$  dBm.  
Record this reading as  $P_O$  to use in step 6.
5. Connect the attenuator output to the FOM.
6. Adjust R2 for an output on the DMM of  $P_O \pm 0.05$  dBm.
7. Repeat steps 1 through 6 until the FOM's -10 dBm and -45 dBm readings are within specifications.
8. Apply insulating varnish, such as red GLPT, to the R10 and R2 potentiometers.

### 850 nm Calibration Adjustment

1. Set the switch on the FOM to the 850 nm position.
2. Connect the light source to the reference power meter. Set the 850 nm light source for a power meter reading of  $-10 \pm 0.05$  dBm.  
Record this level as  $P_O$  to use in step 4.
3. Connect the 850 nm light source to the FOM. Connect the FOM to the DMM.
4. Adjust R1 for an output on the DMM of  $P_O \pm 0.05$  dBm.
5. Apply insulating varnish, such as red GLPT, to the R1 potentiometer.

### 1550 nm Calibration Adjustment

1. Set the switch on the FOM to the 1550 nm position.
2. Connect the light source to the reference power meter. Set the 1550 nm light source to  $-10 \pm 0.05$  dBm.  
Record this reading as  $P_O$  to use in step 4.
3. Connect the 1550 nm light source to the FOM. Connect the FOM to the DMM.
4. Adjust R3 for an output on the DMM of  $P_O \pm 0.05$  dBm.
5. Apply insulating varnish, such as red GLPT, to the R3 potentiometer.

At this point, the calibration adjustment is complete.

### Verifying Calibration

Follow the procedure under "Performance Tests" earlier in this document.

## Calibration Adjustments for the FOS

Refer to the FOS drawing (Figure 2) for the locations of components.

1. Connect the FOS to the calibrated FOM with a patch cable. Turn the FOS on and let it stabilize for 20 minutes.
2. Connect the FOM to a DMM with at least 0.1 mV resolution. Turn the FOM on and set it to the desired wavelength.

3. For 850 nm calibration, adjust R21 until the output on the DMM reads  $-20 \pm 0.1$  mV. For 1300 nm calibration, adjust R20 until the output on the DMM reads  $-20 \pm 0.1$  mV.
4. Apply insulating varnish, such as red GLPT, to each potentiometer adjusted.

## Parts and Accessories

Tables 3 and 4 contain replacement parts for the FOM and FOS that are available from Fluke. Table 5 lists available accessories.

**Table 3. Fluke Replacement Parts for the FOM**

Description	Fluke Part Number
FOM Plastic Case Assembly	617339
Battery Door	200474
Slide Switch Actuator	200482
PD1: Germanium Photodiode, 1 mm	602788

**Table 4. Fluke Replacement Parts for the FOS**

Description	Fluke Part Number
FOS-850 Plastic Case Assembly	617354
FOS-1300 Plastic Case Assembly	617388
FOS-850/1300 Plastic Case Assembly	617412
Battery Door	200474
Slide Switch Actuator	200482
850 LED	602755
1300 LED	602760

**Table 5. Accessories for the FOM and FOS**

Description	Fluke Part Number
ST to ST Multimode Patch Cable, 1m	617453
ST to ST Mating Sleeve	602810
ST to FC Patch Cable	617487
ST to SC Patch Cable	617511
ST to SMA Patch Cable	616545

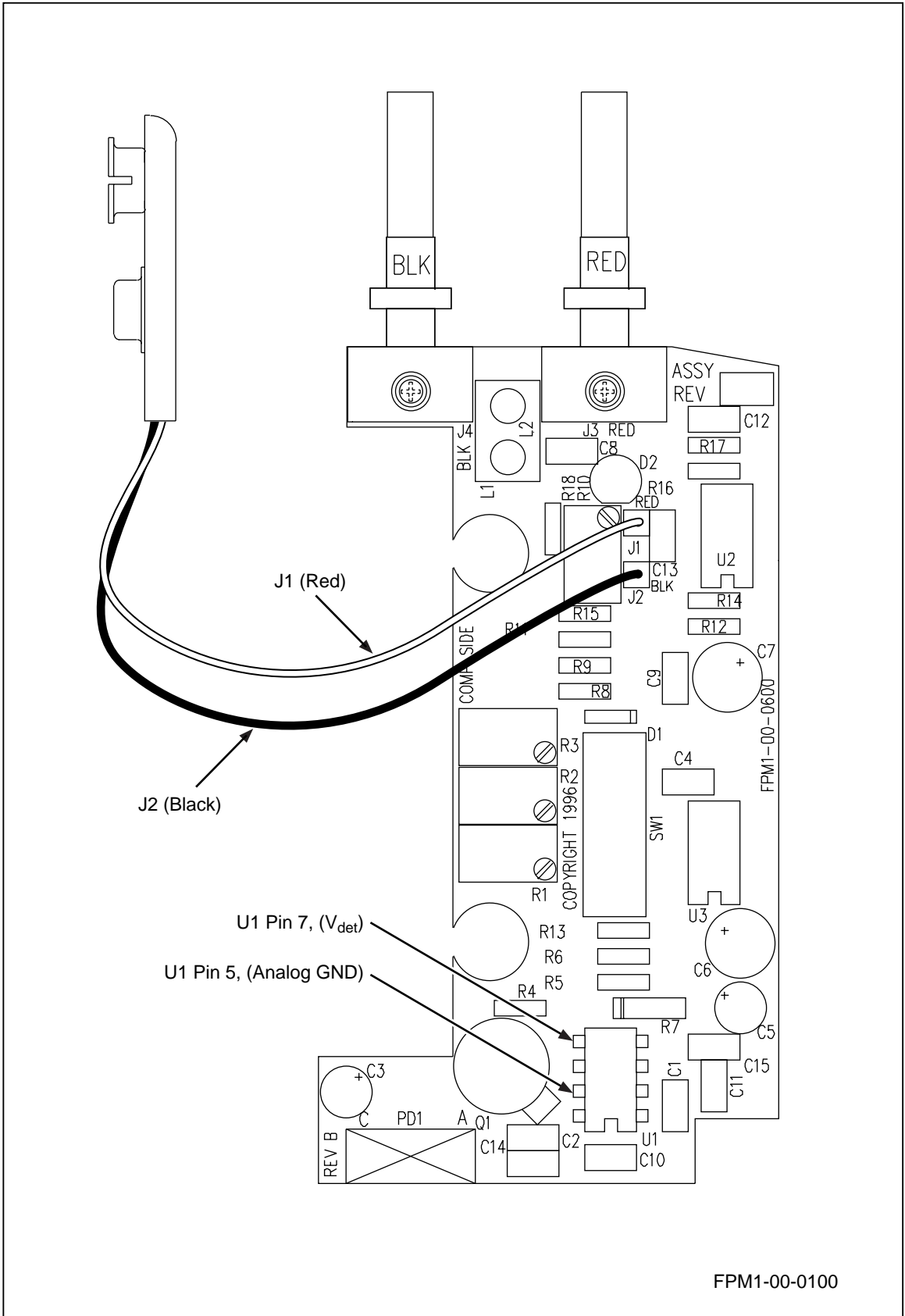
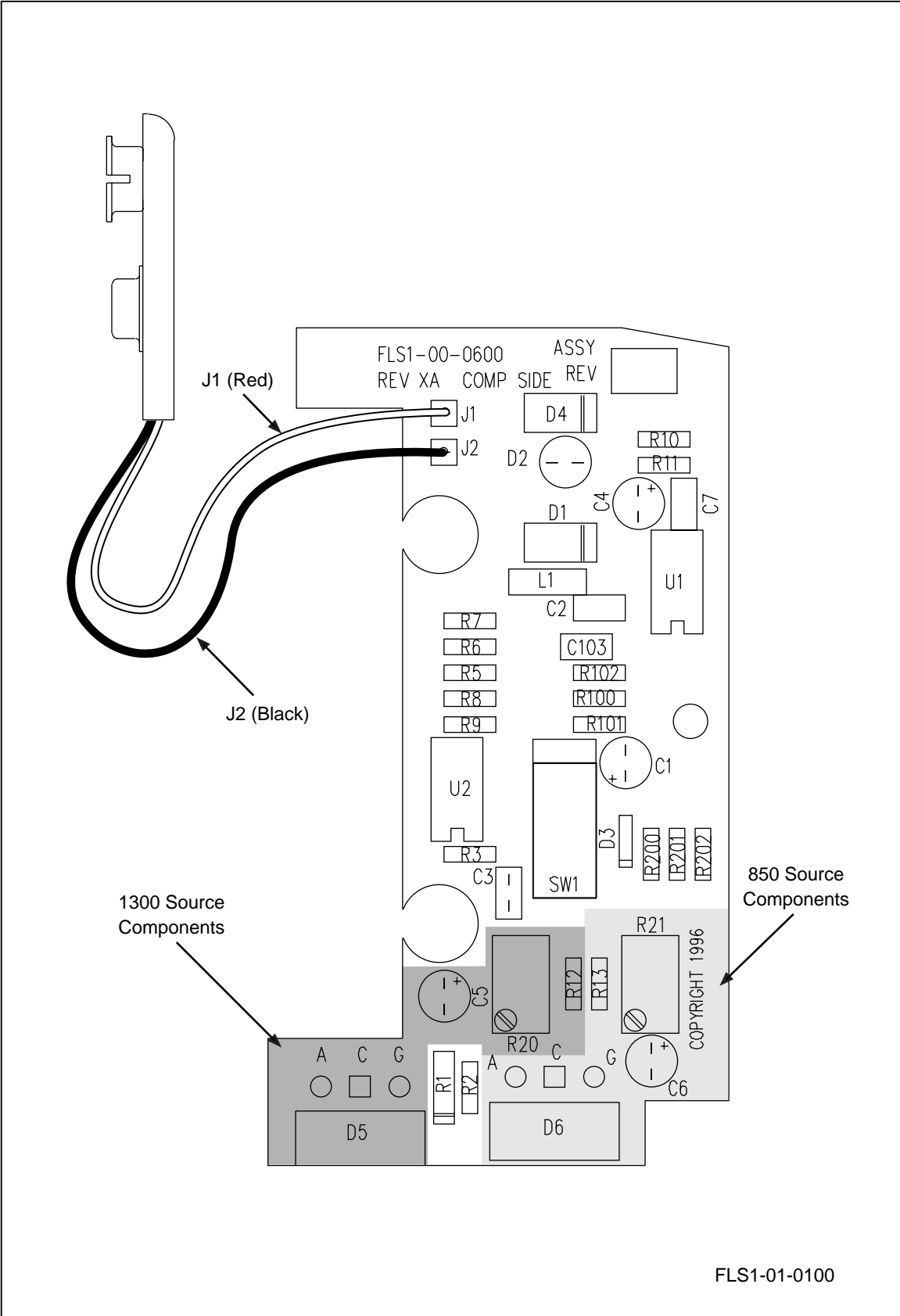

Figure 1. FOM Calibration Measurement and Adjustment Points

eq1f.eps



**Figure 2. FOS Calibration Adjustment Points**

eq2f.eps





